

Application Note 334

Interfacing a Bit Error-Rate Tester to Dallas Semiconductor Framers and Transceivers

www.maxim-ic.com

INTRODUCTION

This application note shows a how to connect a Dallas BERT to a Dallas framer/single-chip transceiver (SCT). This application note applies to the following products:

T1 FRAMERS	E1 FRAMERS	T1 SCTs	E1 SCTs	T1/E1 SCTs
DS2141	DS2143	DS2151	DS2153	DS2156
DS21Q41	DS21Q43	DS2152	DS2154	DS2155
DS21Q42	DS21Q44	DS21352	DS21354	DS21Q55
DS21FF42	DS21FF44	DS21552	DS21554	DS21455
DS21FT42	DS21FT44	DS21Q552	DS21Q554	DS21458
		DS21Q352	DS21Q354	

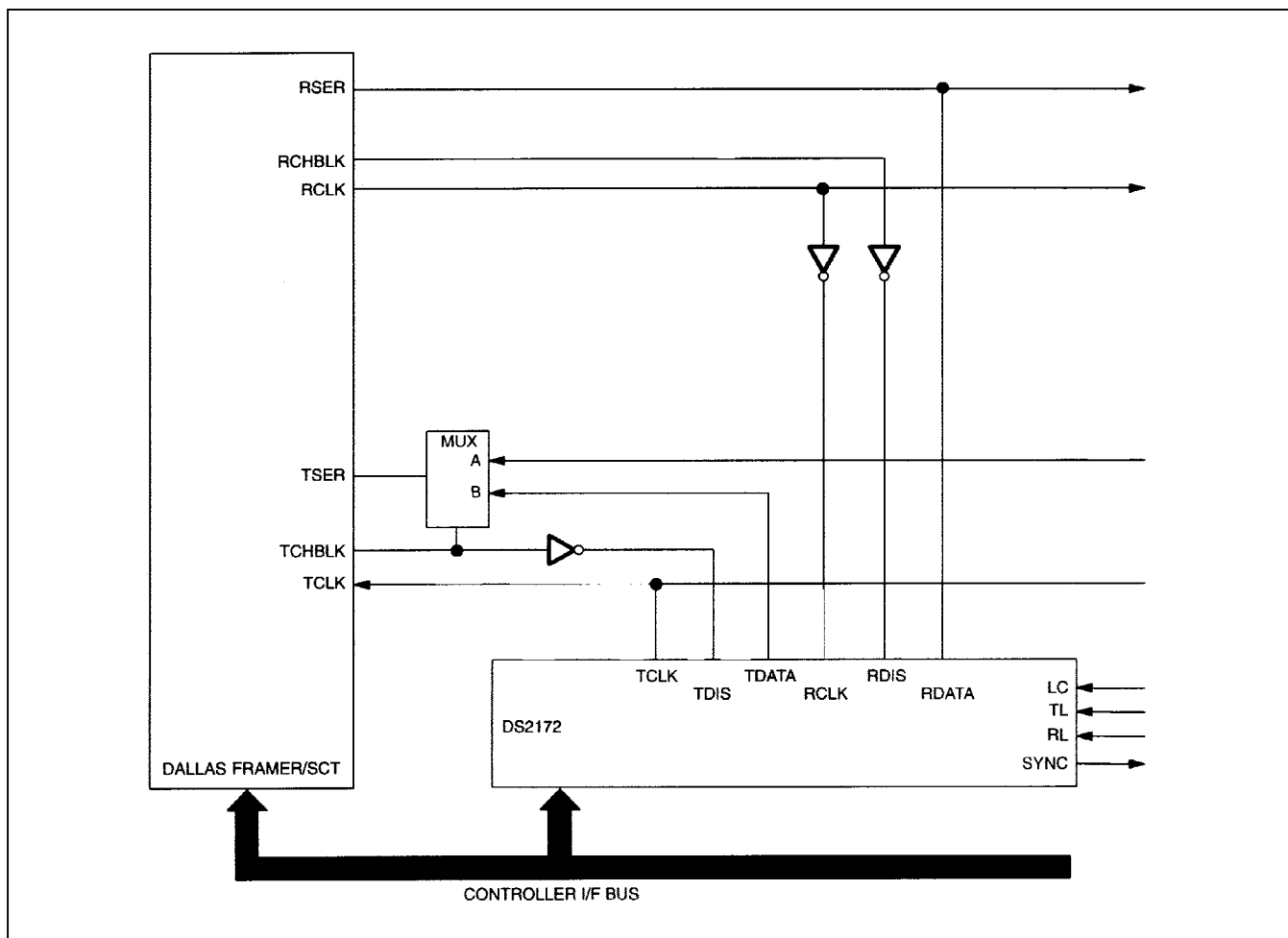

Figure 1. Framer/SCT to DS2172/DS21372 Interface

GENERAL CONFIGURATION

The circuit in Figure 1 describes a method of interfacing the DS2172/DS21372 bit error-rate tester (BERT) to the Dallas Semiconductor family of T1/E1 framers and single-chip transceivers. This diagram illustrates how the BERT can be used in a real system with the use of a multiplexer to determine whether to put the system in test mode and use the BERT or to disable the BERT and send normal data. The receive side of the DS2172/DS21372 can be connected directly to the receive-data stream of the framer/SCT. The DS21372 is a 3.3V version of the DS2172.

The RCHBLK and TCHBLK outputs from the framer/SCT are used to determine the time slot or band in which the BERT is to transmit or receive data. These pins are programmed using the RCHBLK/TCHBLK registers. The RCHBLK/TCHBLK pins are normally low; writing the register bits to one will set the pin to a high voltage during that time slot. In this configuration, setting the RCHBLK and TCHBLK pins high enables the DS2172/DS21372 to transmit and receive data.

Figure 1 shows the DS21x5y with the elastic stores disabled. If the elastic stores are enabled, the user will use the system clock (TSYSCLK, RSYSCLK) as inputs to the DS2172/DS21372 rather than RCLK and TCLK.

Note: In T1 framers/SCTs, the TCHBLK/RCHBLK pin cannot be configured to be high during the F-bit position. This means the DS2172/DS21372 cannot source data during the F-bit position of each frame. E1 framers/SCT TCHBLK/RCHBLK can be programmed to be high during the entire frame. Listed below are the TCHBLK/RCHBLK registers for any E1 framer or any E1-only SCT listed above.

RCBR1/RCBR2/RCBR3/RCBR4: RECEIVE-CHANNEL BLOCKING REGISTERS

(Address = 2B to 2E Hex)

(MSB)

(LSB)

CH8	CH7	CH6	CH5	CH4	CH3	CH2	CH1	RCBR1 (2B)
CH16	CH15	CH14	CH13	CH12	CH11	CH10	CH9	RCBR2 (2C)
CH24	CH23	CH22	CH21	CH20	CH19	CH18	CH17	RCBR3 (2D)
CH32	CH31	CH30	CH29	CH28	CH27	CH26	CH25	RCBR4 (2E)

NAME	POSITION	FUNCTION
CH1–32	RCBR1.0–4.7	Receive-Channel Blocking Control Bits 0 = force the RCHBLK pin to remain low during this channel time 1 = force the RCHBLK pin high during this channel time

TCBR1/TCBR2/TCBR3/TCBR4: TRANSMIT-CHANNEL BLOCKING REGISTERS

(Address = 22 to 25 Hex)

(MSB)

(LSB)

CH8	CH7	CH6	CH5	CH4	CH3	CH2	CH1	TCBR1 (22)
CH16	CH15	CH14	CH13	CH12	CH11	CH10	CH9	TCBR2 (23)
CH24	CH23	CH22	CH21	CH20	CH19	CH18	CH17	TCBR3 (24)
CH32	CH31	CH30	CH29	CH28	CH27	CH26	CH25	TCBR4 (25)

NAME	POSITION	FUNCTION
CH1–32	TCBR1.0–4.7	Transmit-Channel Blocking Control Bits 0 = force the TCHBLK pin to remain low during this channel time 1 = force the TCHBLK pin high during this channel time

Listed below are the TCHBLK/RCHBLK registers for any T1 framer or any T1-only SCT listed above.

RCBR1/RCBR2/RCBR3: RECEIVE-CHANNEL BLOCKING REGISTERS

(Address = 6C to 6E Hex)

(MSB)

(LSB)

CH8	CH7	CH6	CH5	CH4	CH3	CH2	CH1	RCBR1 (6C)
CH16	CH15	CH14	CH13	CH12	CH11	CH10	CH9	RCBR2 (6D)
CH24	CH23	CH22	CH21	CH20	CH19	CH18	CH17	RCBR3 (6E)

NAME	POSITION	FUNCTION
CH1–24	RCBR1.0–3.7	Receive-Channel Blocking Control Bits 0 = force the RCHBLK pin to remain low during this channel time 1 = force the RCHBLK pin high during this channel time

TCBR1/TCBR2/TCBR3: TRANSMIT-CHANNEL BLOCKING REGISTERS

(Address = 32 to 34 Hex)

(MSB)

(LSB)

CH8	CH7	CH6	CH5	CH4	CH3	CH2	CH1	TCBR1 (32)
CH16	CH15	CH14	CH13	CH12	CH11	CH10	CH9	TCBR2 (33)
CH24	CH23	CH22	CH21	CH20	CH19	CH18	CH17	TCBR3 (34)

NAME	POSITION	FUNCTION
CH1–24	TCBR1.0–3.7	Transmit-Channel Blocking Control Bits 0 = force the TCHBLK pin to remain low during this channel time 1 = force the TCHBLK pin high during this channel time

CONCLUSION

This application note has shown how to connect our framers/SCTs to our DS2172/DS21372 BERT.

If you have further questions about connecting any of our framers/SCTs to our BERTs, then please contact the Telecommunication Applications support team via email telecom.support@dalsemi.com or call 972-371-6555.

DALLAS FRAMER/SCT AND BERT INFORMATION

For more information about our framers/SCTs or BERTs, please consult the data sheets available on our website at www.maxim-ic.com/telecom.